

52nd Pacific Northwest Regional Economic Conference



Rough Roads Ahead 2

Economic Implications of
Deteriorating Highway
Conditions

**Coauthor
Alex Bettinardi**

Becky Knudson, Oregon DOT

May 23, 2018



Highway Condition Impacts the Economy



**The Cost of Poor Highway Conditions
to Oregon's Economy**

Available online:
[http://www.oregon.gov/ODOT/Planning/
Documents/Rough-Roads-Ahead-1.pdf](http://www.oregon.gov/ODOT/Planning/Documents/Rough-Roads-Ahead-1.pdf)



2014

Rough Roads Ahead 2

**Economic Implications of
Deteriorating Highway Conditions**

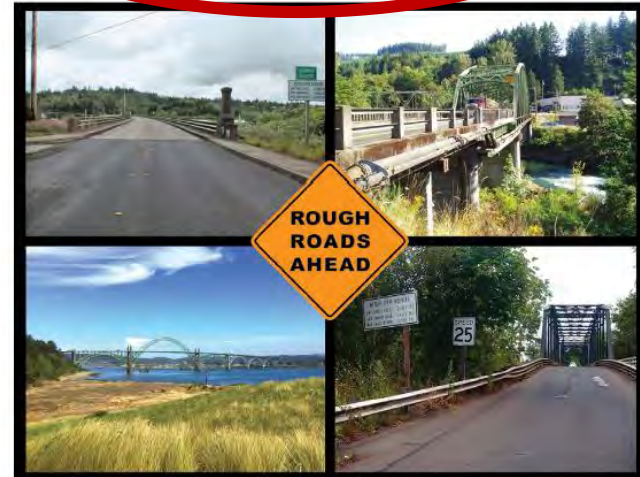

Available online:
[http://www.oregon.gov/ODOT/Planning/
Documents/Rough-Roads-Ahead-2.pdf](http://www.oregon.gov/ODOT/Planning/Documents/Rough-Roads-Ahead-2.pdf)

2017

Scenario 1 Budget

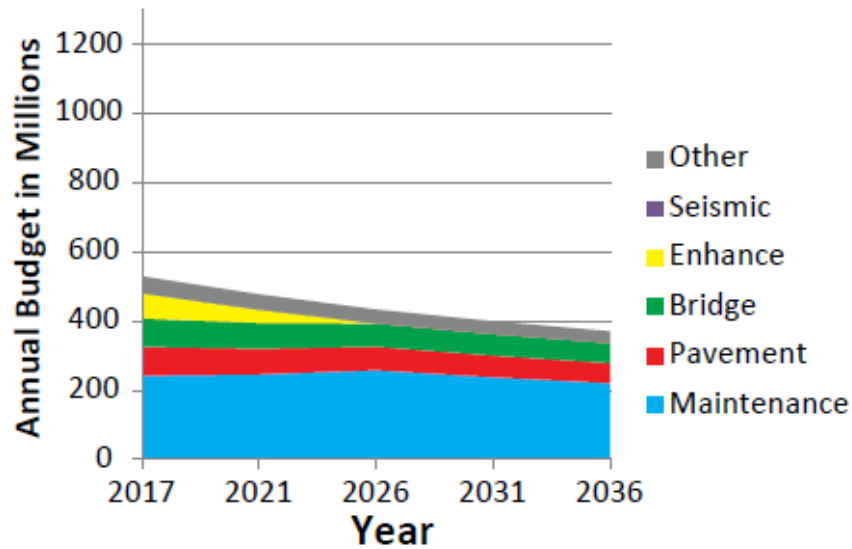

Scenario 2 Budget

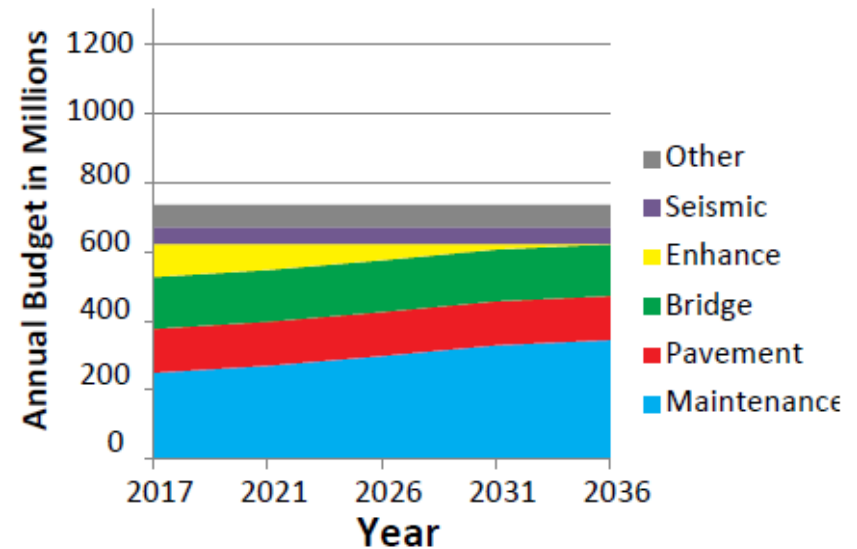

Scenario 3 Budget

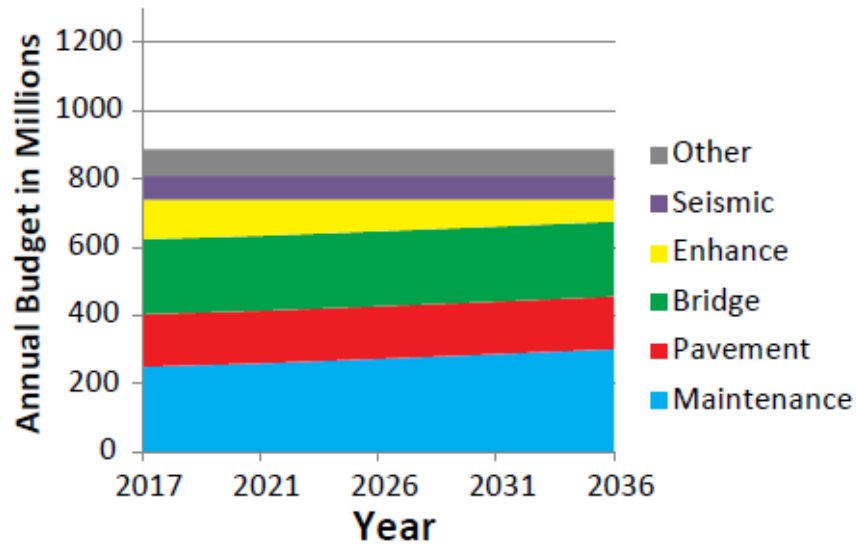

Scenario 4 Budget

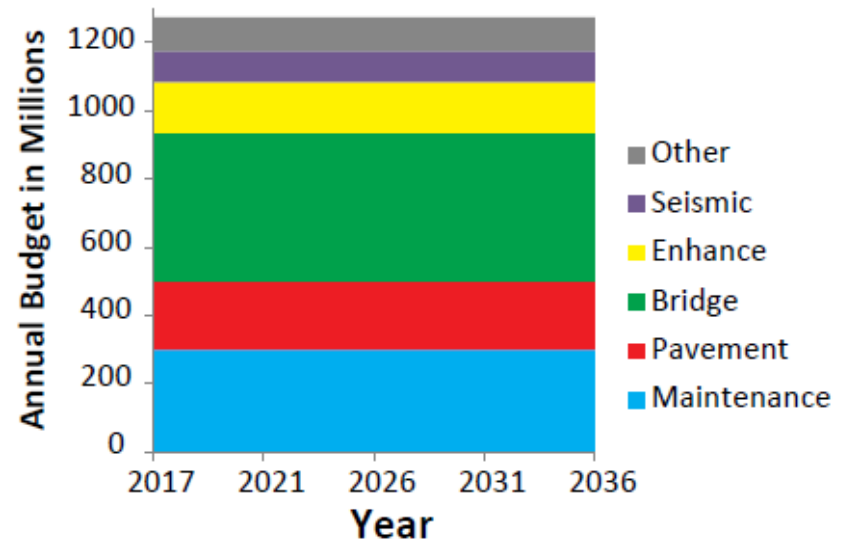

Scenario 1 Budget

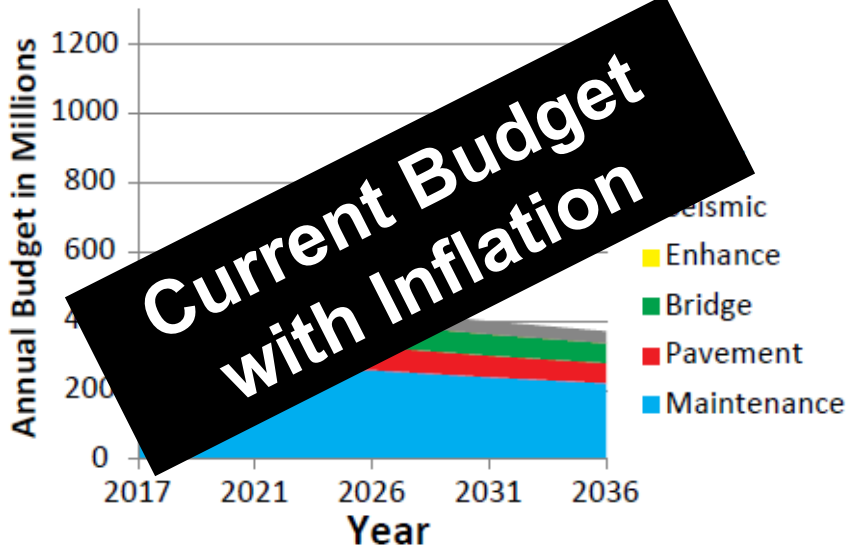

Scenario 2 Budget

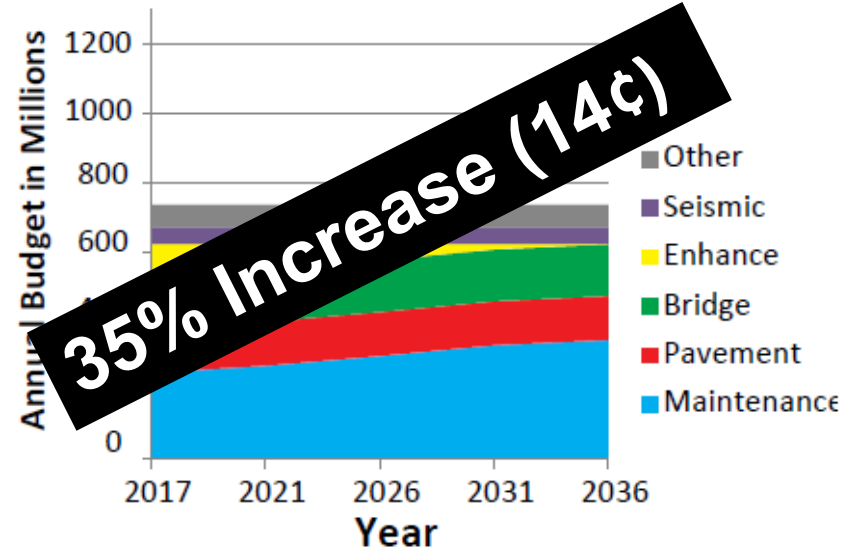

Scenario 3 Budget

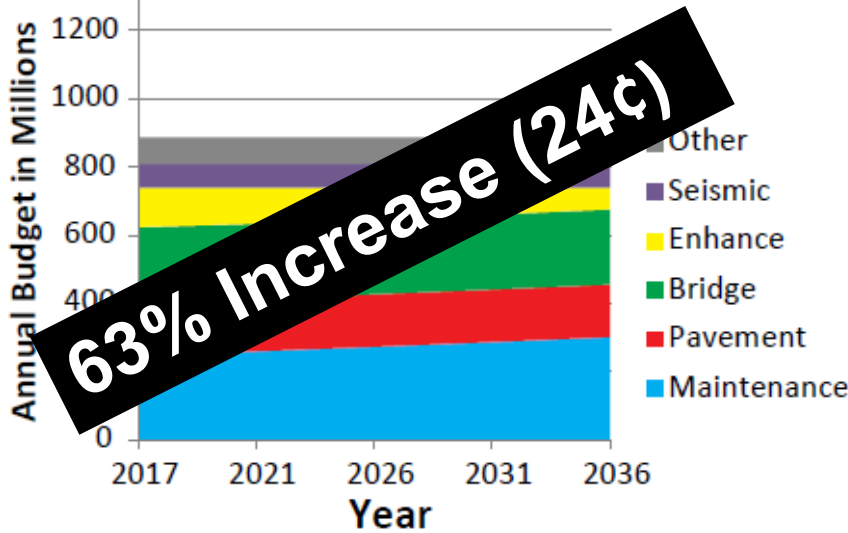

Scenario 4 Budget

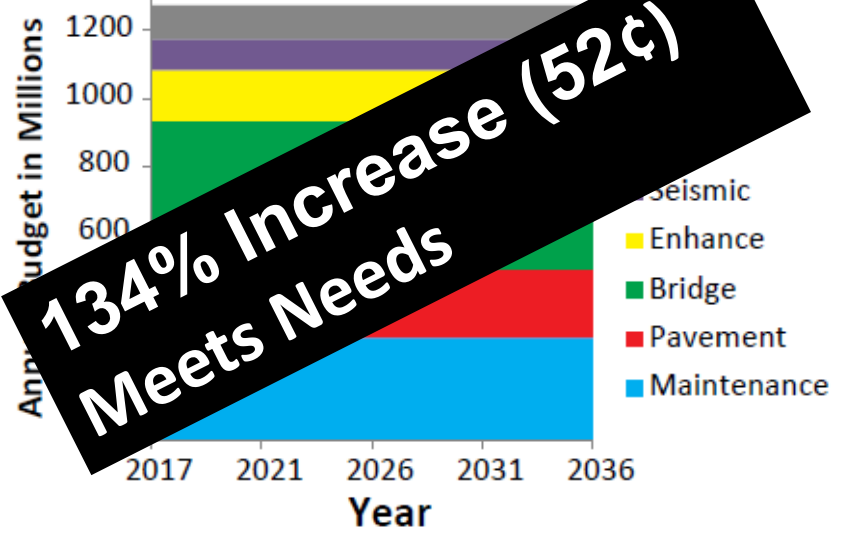

Methodology: Tools



ODOT Bridge Model

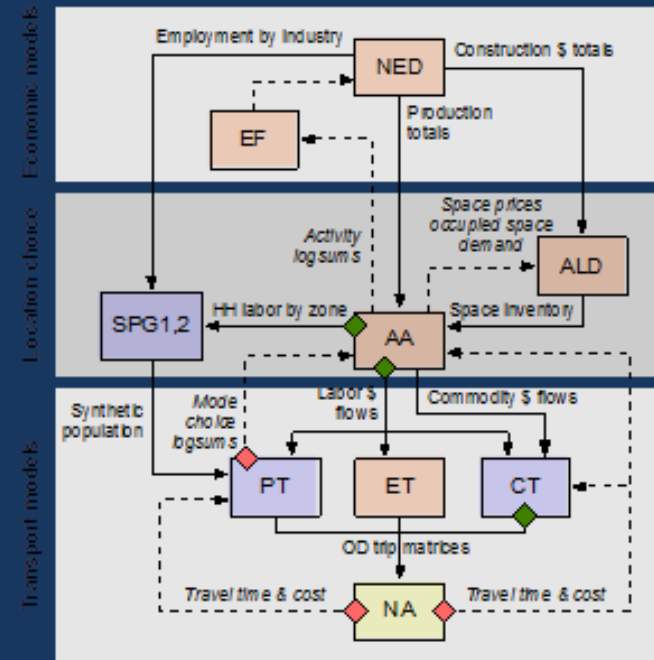

Oregon Statewide Integrated Model V2.5

Bridge Model

Bridge Conditions: Current & 2036 Forecast by Scenario

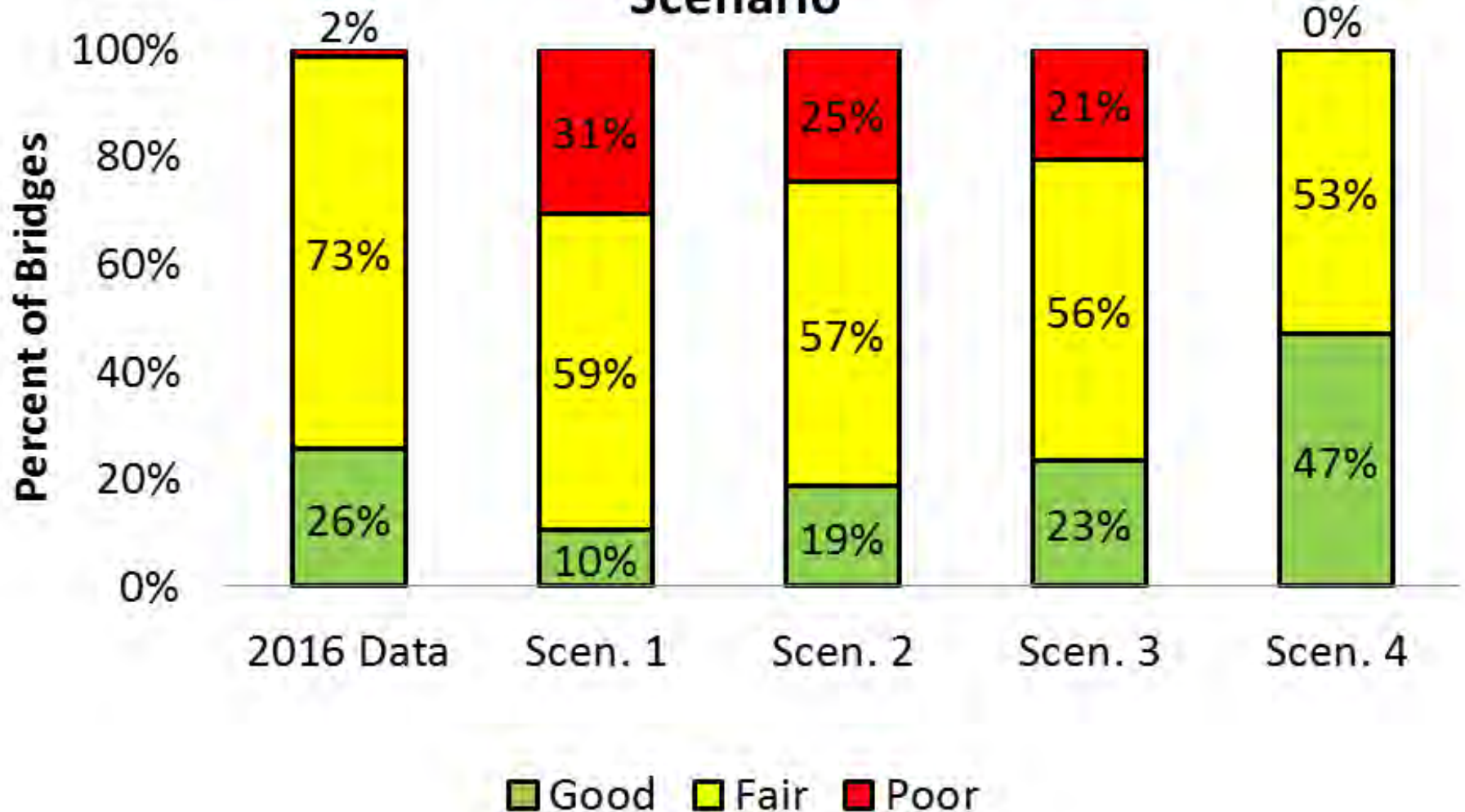

SWIM Schematic

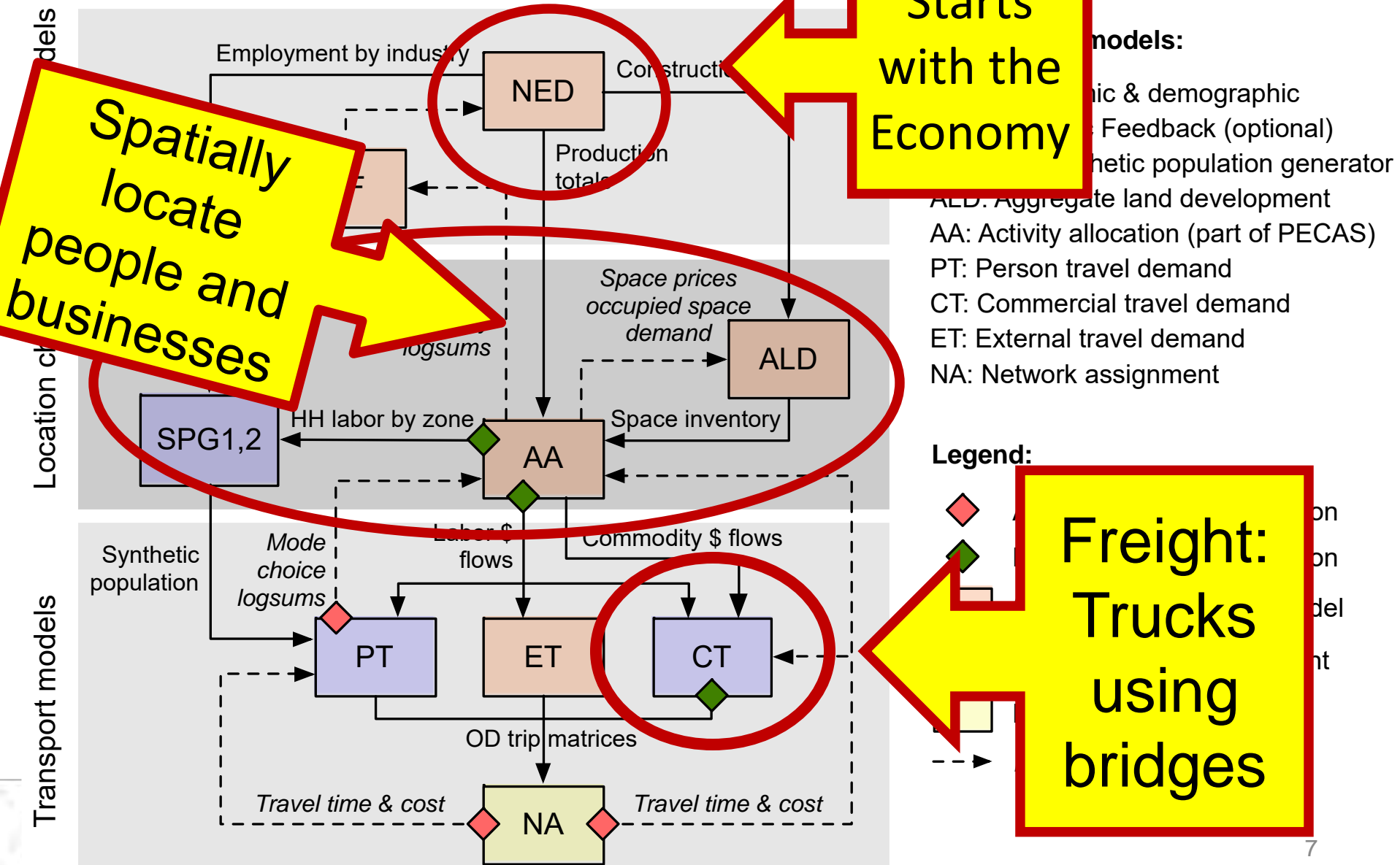

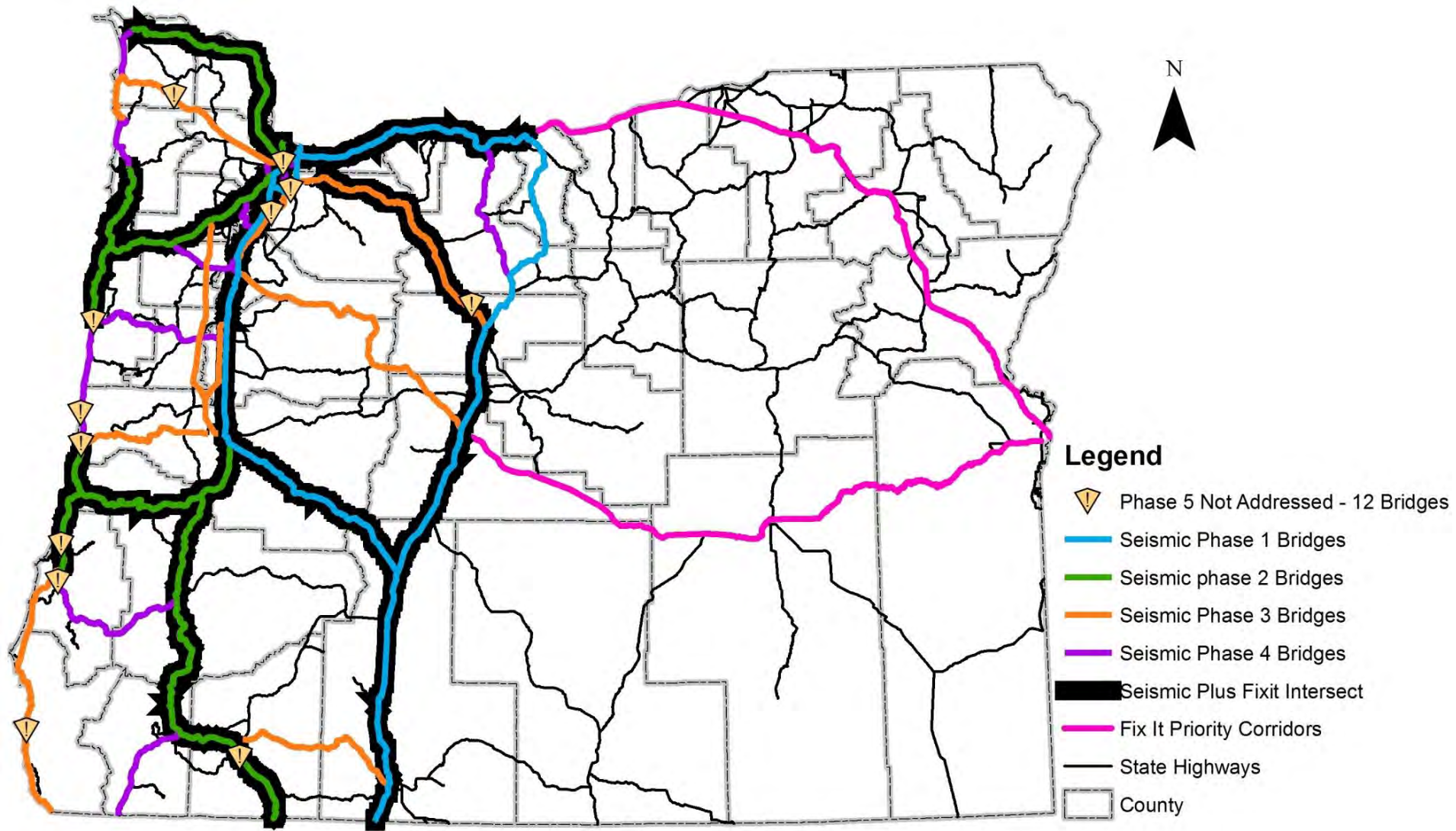

Priority Corridors



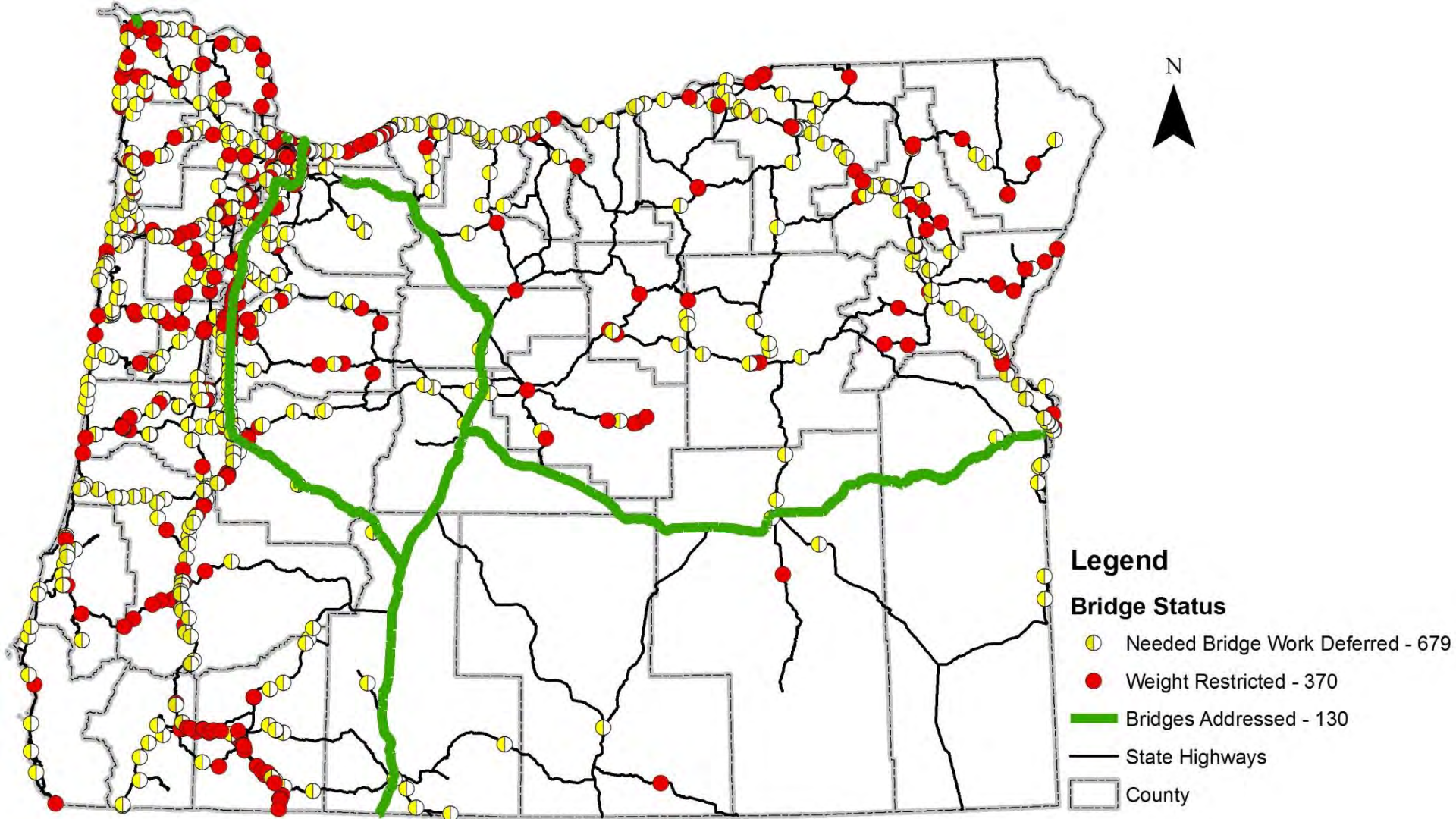

Current Budget Scenario

Treat 130 Bridges Weight Restrict 370

Defer work on 679 No Seismic Investment

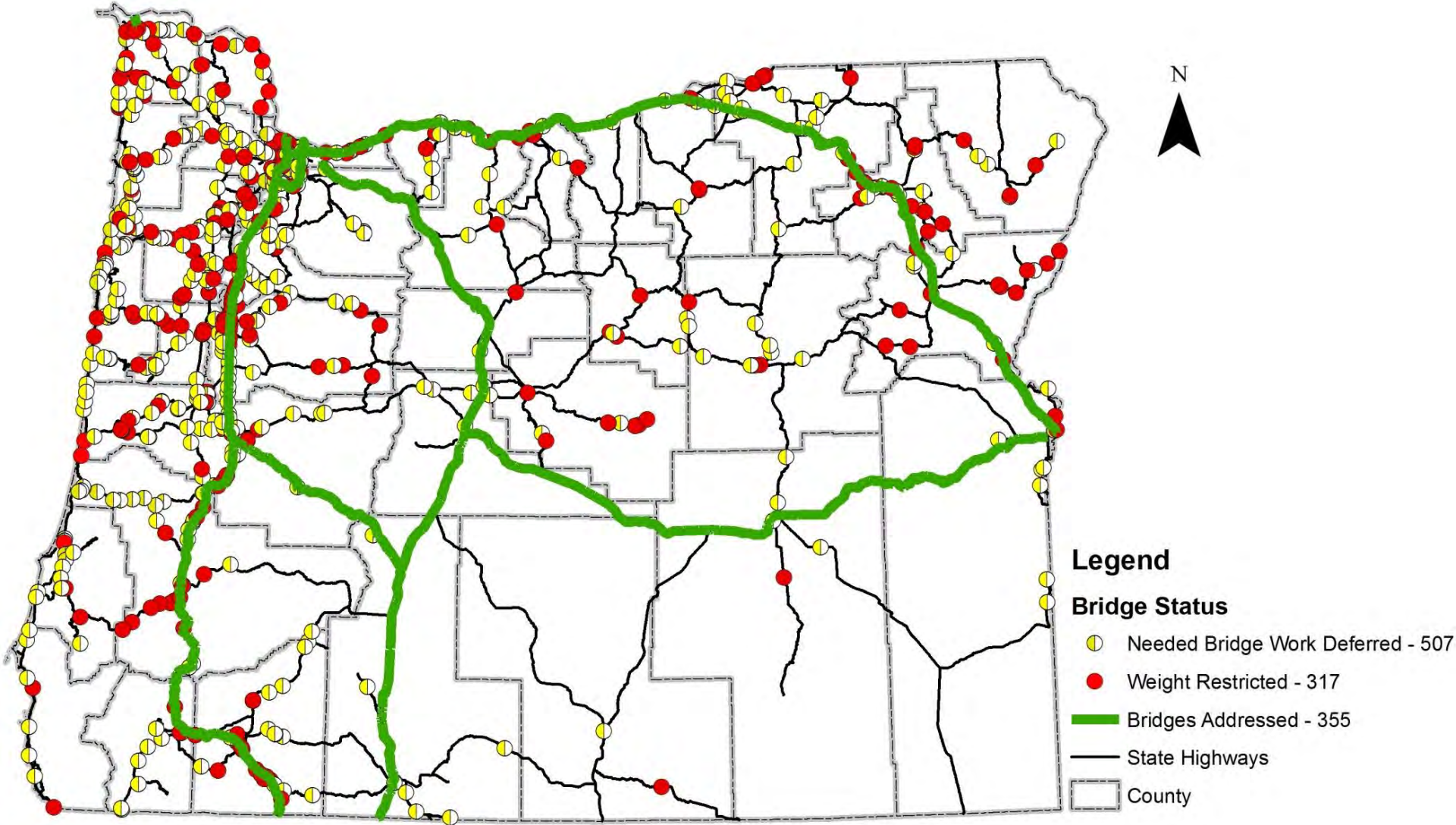

Scenario 2

**Treat 355 Bridges Weight Restrict 317
Defer work on 507 Seismic \$49M**

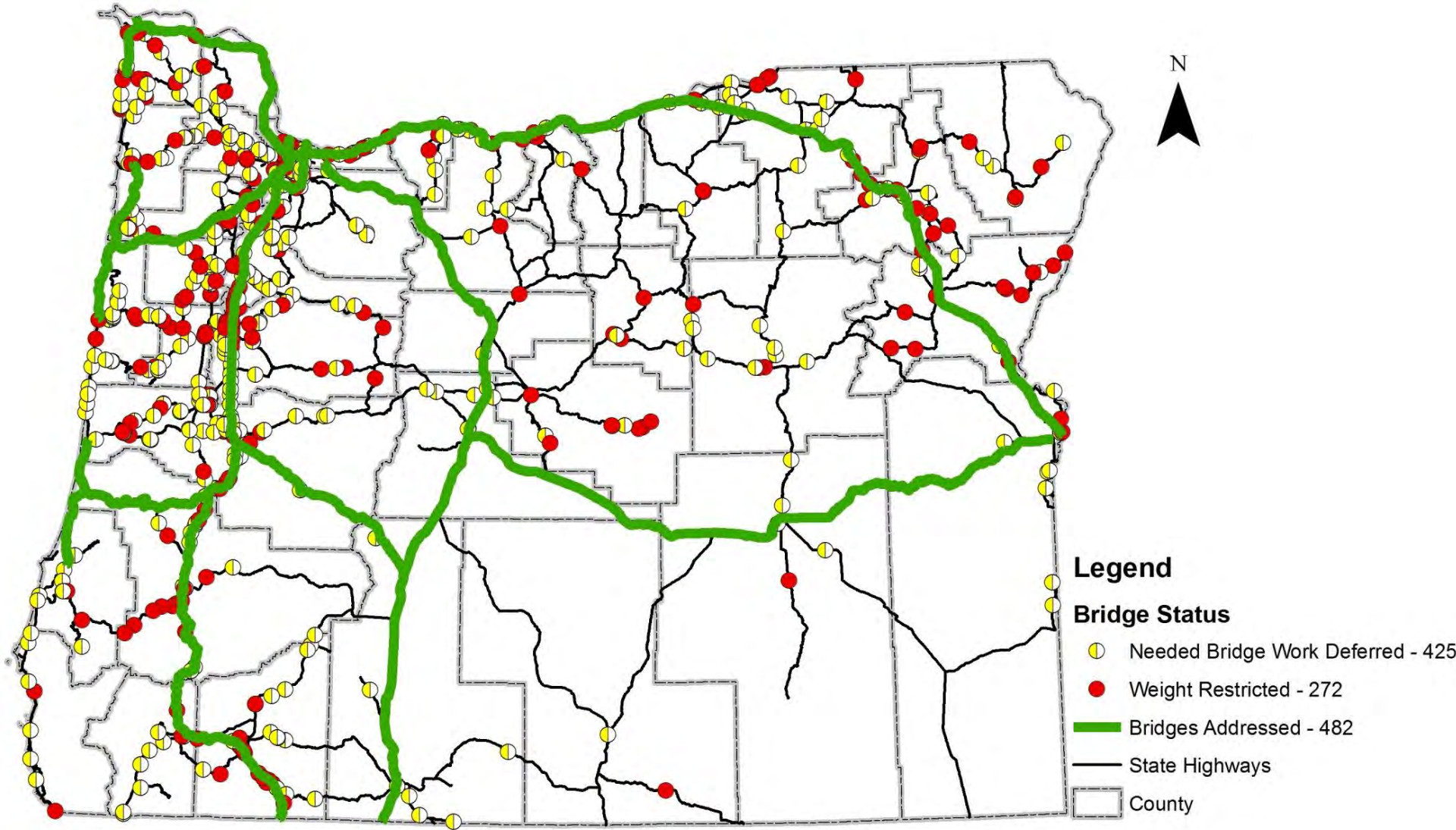

Scenario 3

**Treat 482 Bridges Weight Restrict 272
Defer work on 425 Seismic \$70**

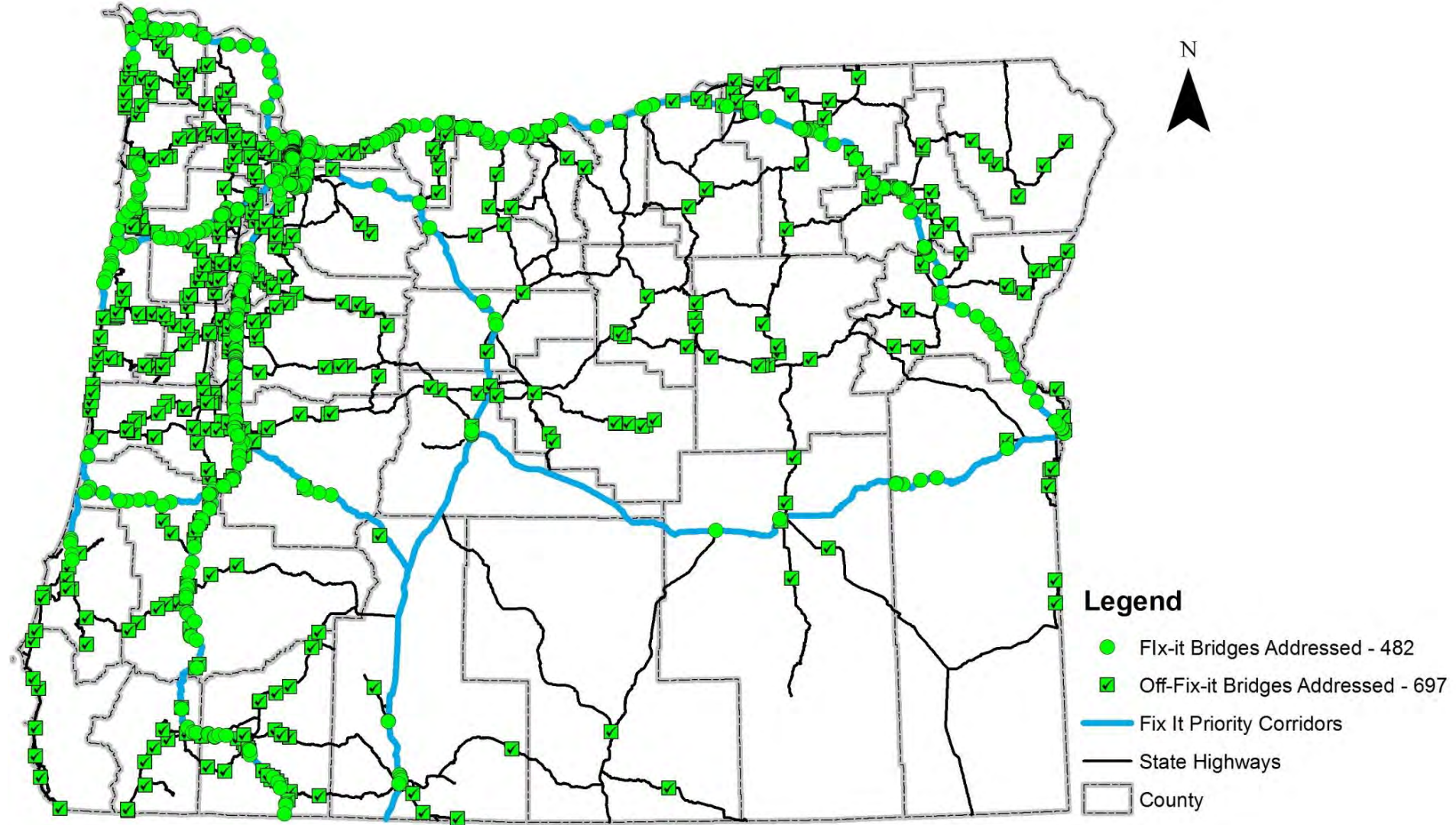

Scenario 4

Treat 1179 Bridges Weight Restrict 0
Defer work on 0 Seismic \$90M

Economic Impacts

Jobs



Domestic Product



Forfeit Employment Statewide

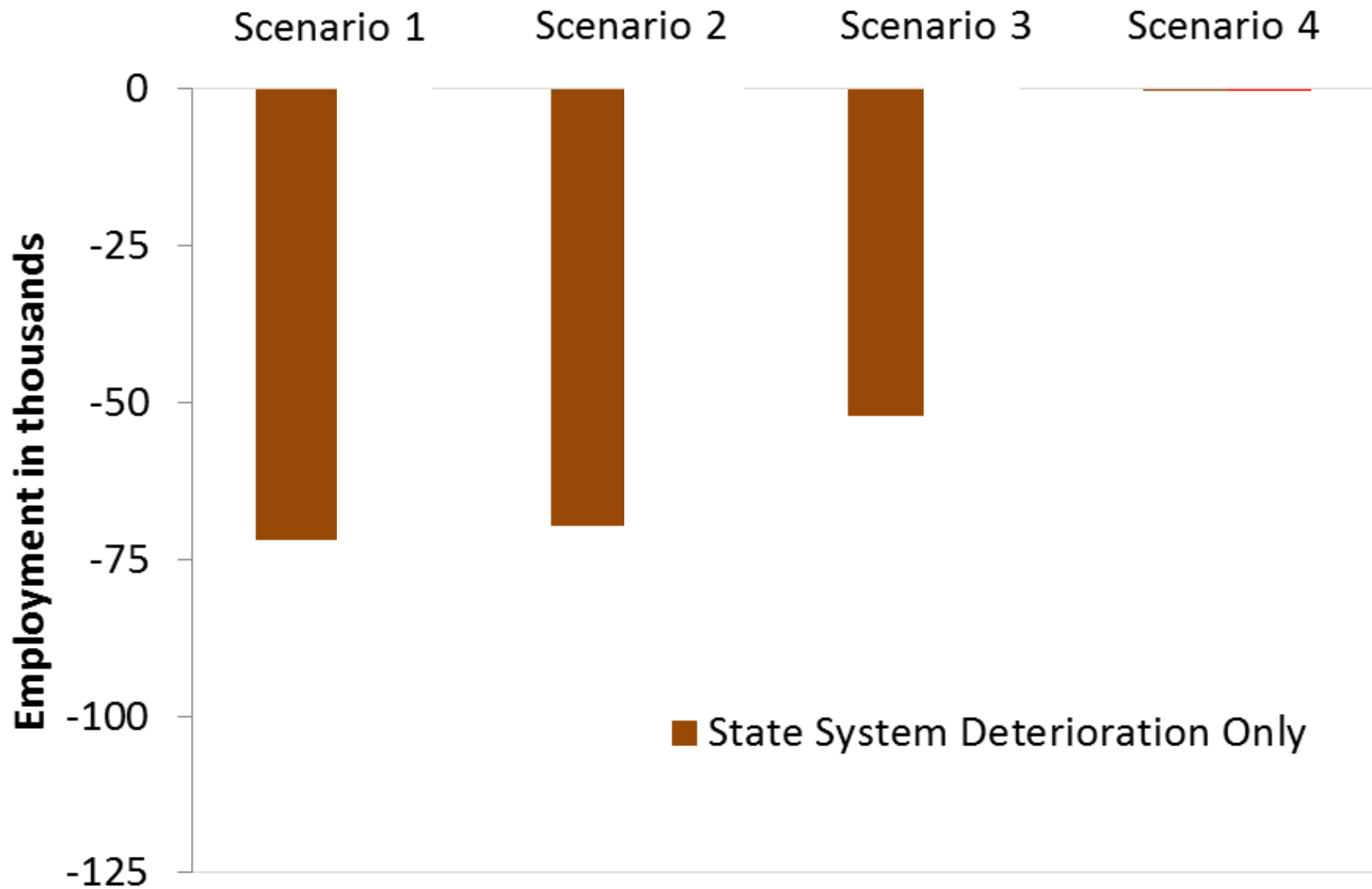

Forfeit Employment Statewide

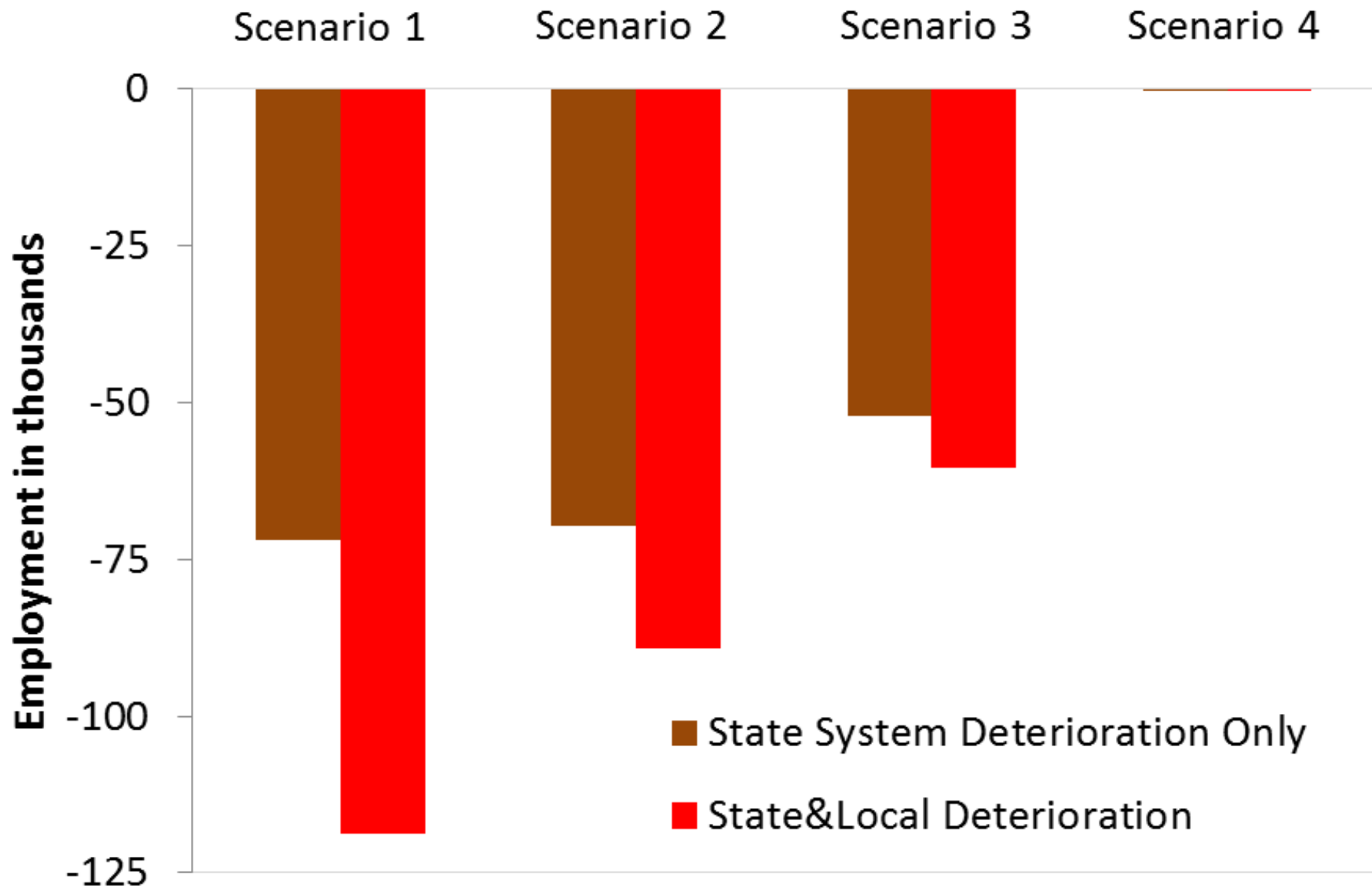

Potential Cumulative Losses to Oregon GDP

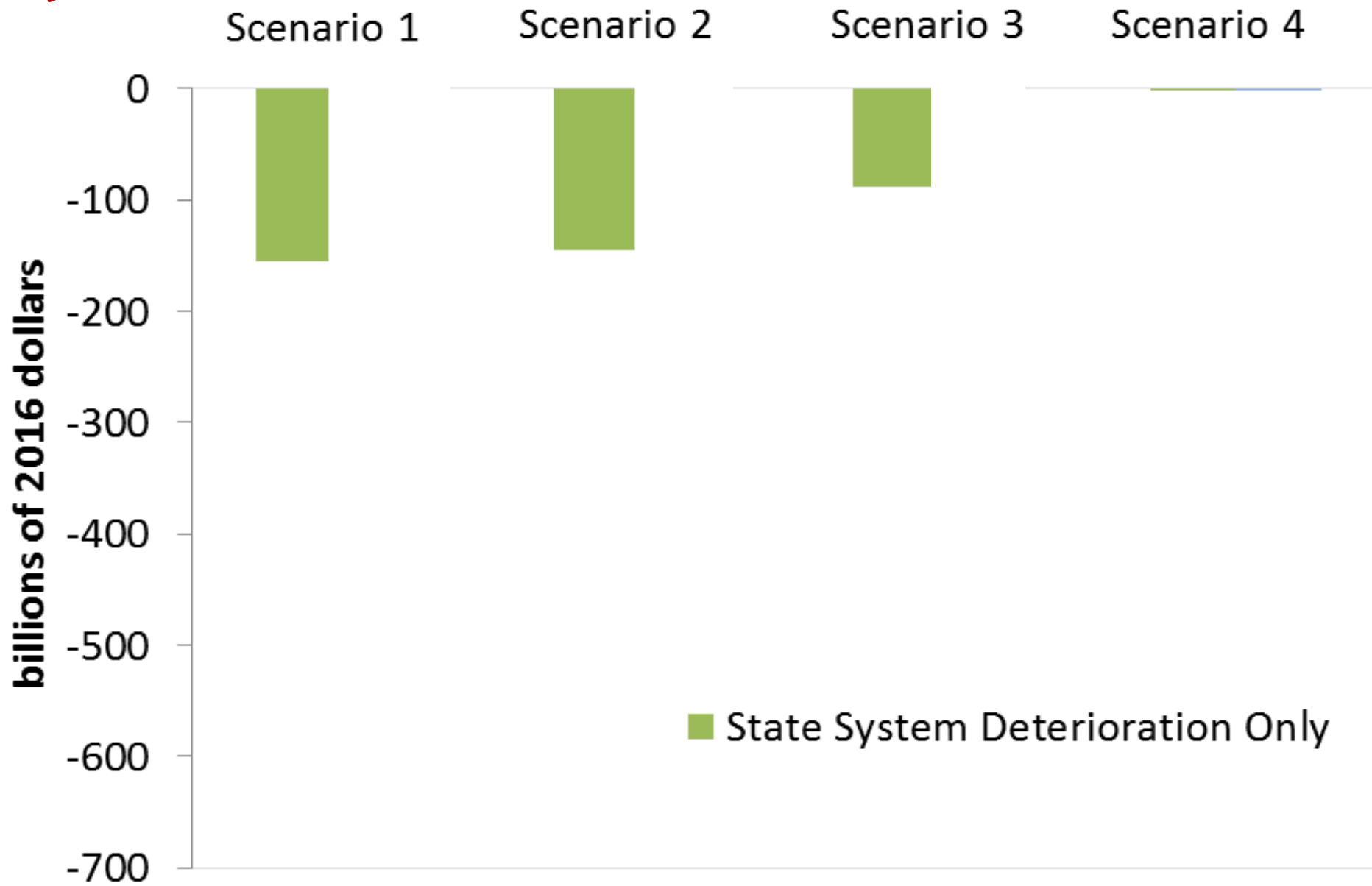

Potential Cumulative Losses to Oregon GDP

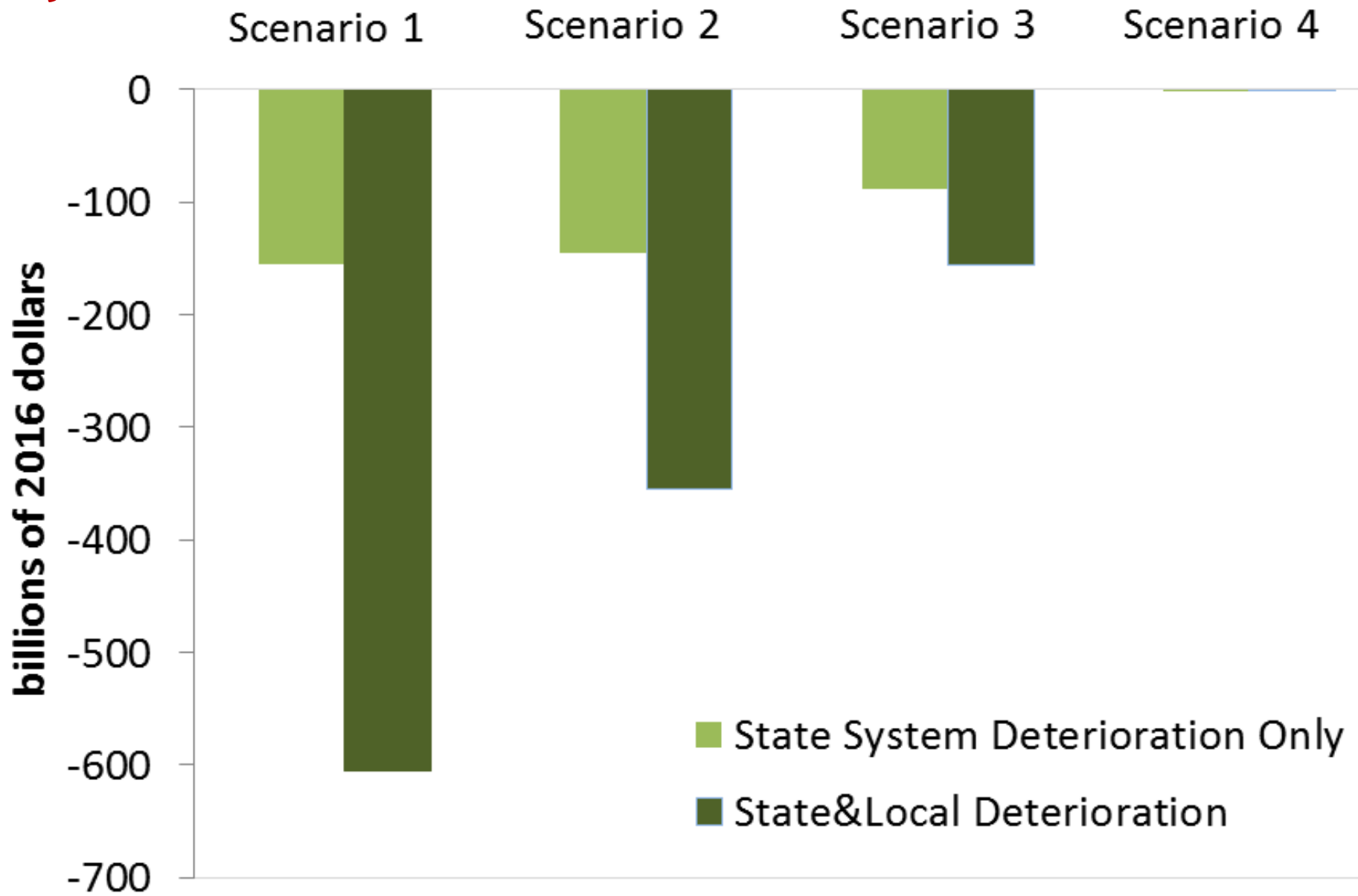



**ODOT
Pavement
Model &
NCHRP
Report 720**

**Rough Pavement Increases
Vehicle Operating Costs**



Rough Pavement Increases Vehicle Operating Costs



Driving 20% of vehicle-miles of travel on rough pavement increases operating costs over 4%, which translates into over \$300 million increase in annual spending

- ↓ Fuel efficiency declines
- ↑ Oil and tire costs rise
- ↑ Repair costs rise



Rough Pavement Impacts Safety



Vehicle-miles
rough
increases
over 4%,
into over
increase in
ending



Repair costs rise

Closing Thoughts

Key Features of Success

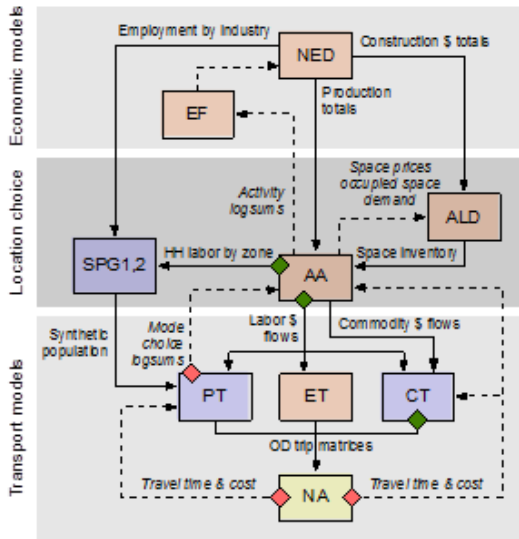

Economic
Land-Use
Transport
Model

Teamwork
and
Collaboration

House Bill 2017
TRANSPORTATION
FUNDING





Becky Knudson

**Senior Transportation Economist
Transportation Planning Analysis Unit
Oregon Department of Transportation
rebecca.a.knudson@odot.state.or.us**

Alex Bettinardi

**Senior Integrated Analysis Engineer
Transportation Planning Analysis Unit
Oregon Department of Transportation
alexander.o.bettinardi@odot.state.or.us**

Full Report Available online:

<http://www.oregon.gov/ODOT/Planning/Documents/Rough-Roads-Ahead-2.pdf>

Modeling Program Retrospective Journal Article:

<http://www.oregon.gov/ODOT/Planning/Documents/JTLU-TLUMIP-Retrospective.pdf>

